

YAMAHA PG-1 (23) STREET SPORTS FULL SYSTEM GP-MAGNUM TYPE UP

Be sure to read the instruction carefully before starting the work. It is necessary to follow the contents to install Yoshimura product.



- CAUTION** Before beginning installation, let motorcycle cool down.
- CAUTION** Be sure not to damage each part during installation.
- CAUTION** Torque specification must be followed. If neglected, it may cause bolt and nut to fall off and damage to Yoshimura product and motorcycle.
- CAUTION** Titanium Blue sleeve is colored by anodizing. Handle with care as the color may change. When cleaning silencer, use soft cloth with dish soap but do not use metal polish or chemical cleaner.

1. Product Information :

Description	YAMAHA PG-1 (23) SS Full System GP-Magnum Type Up	Cyclone Type	Y378SC111
Part Number	Stainless Sleeve (SS) : 180A-378A5U50	Main Material	Stainless steel
	Satin Finish Sleeve (SF) : 180A-378A5U30	Weight [STD : 4.8kg]	(SS) & (SF) : 3.2kg
	Titanium Blue Sleeve (STB) : 180A-378A5U80B		(ST) : 3.0kg
	Carbon Sleeve (SC) : 180A-378A5U90		(SC) : 2.9kg

2. Applicable Model :

Model	YAMAHA PG-1 (23)
-------	------------------

3. Contents:

No.	Descriptions	Part No.	Q'ty	No.	Descriptions	Part No.	Q'ty
1	Exhaust Pipe	1T1-378-5U00	1	7	Washer M8x26	812-108-2600	2
2	Silencer Assy, SS	186-378-5U50	1	8	Silencer Bracket	161-378-0300	1
	Silencer Assy, SF	186-378-5U30		9	Flange Nut M8	823-008-1250	1
	Silencer Assy, STB	186-378-5U80B		10	U-Nut M10	820-010-1251	1
	Silencer Assy, SC	186-378-5U90		11	Exhaust Spring	118-001-0000	2
	3	Button Bolt M6x20		803-206-4020	2	12	Button Bolt M6x6
4	Washer M6x13	812-206-1310	6	13	Heat Guard	161-378-0000	1
5	Flange Nut M6	823-006-1000	2	※	Spring Puller Tool	100-000-0000	1
6	Cap Bolt M8x20	800-208-5020	1				

4. Optional Part :

Description	Part No.
Heat Guard	161-000-A610

Parts Diagram

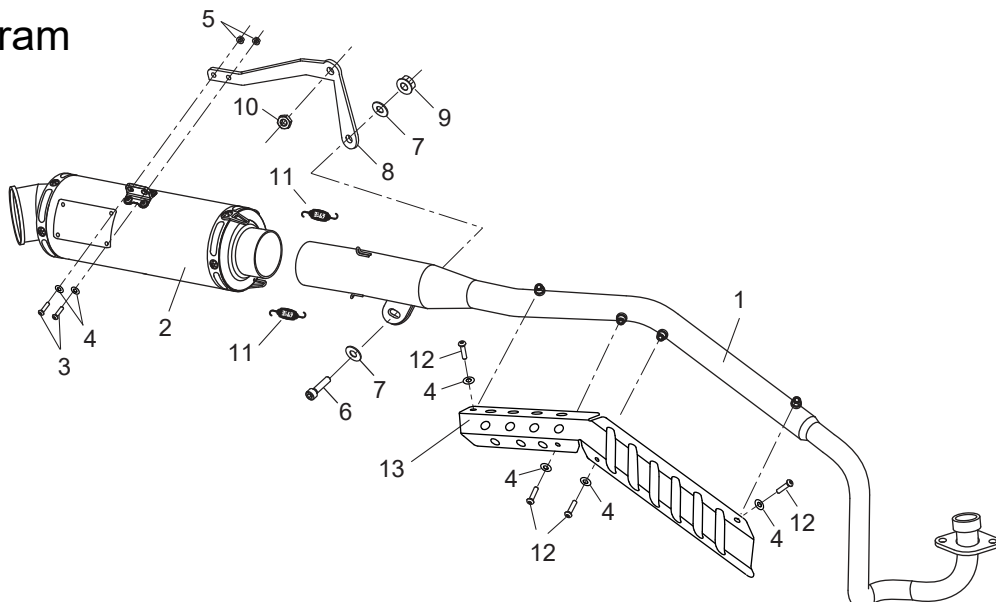

5. Installation steps:

- 1) Check that all the component parts are in hand.
- 2) According to YAMAHA service manual, remove stock exhaust system (See Fig. 1).

CAUTION When removing stock exhaust system, be careful do not to damage frame or other components.

REFERENCE Stock nuts and bolt removed at this stage are reused when mounting Yoshimura product



FIG. 1

- 4) Remove the Stock Bolt M10 and Stock Washer M10 on RH Upper rear suspension mount and attach Silencer Bracket with U-Nut M10 P1.25. Tighten the nut by hand only at this stage. (See Fig. 2 & 3).

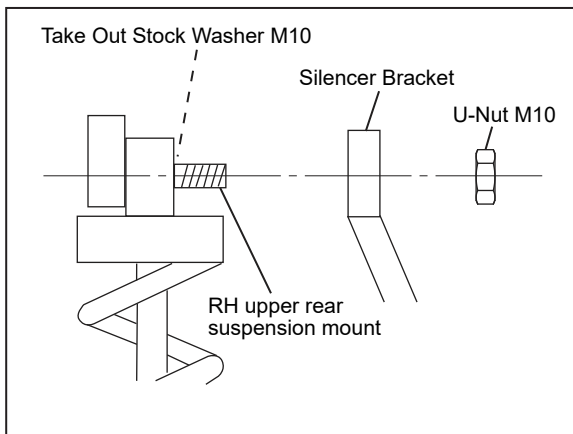

FIG. 2

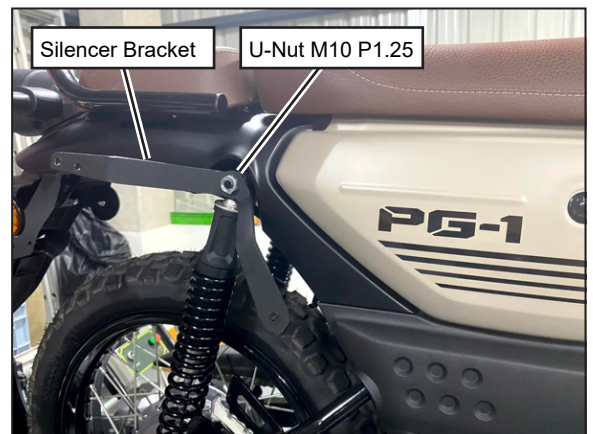

FIG. 3

- 5) Replace stock gasket at exhaust port of engine with new one. Then, mount Exhaust Pipe with stock nuts. Tighten nuts by hand only at this stage. (See Fig. 4 , 5).

CAUTION Use YAMAHA genuine new exhaust gasket.

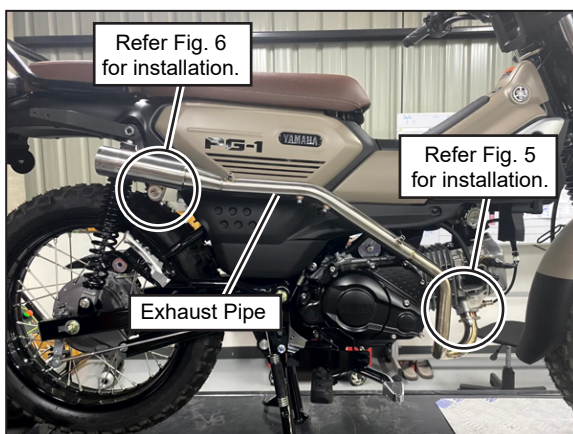

FIG. 4

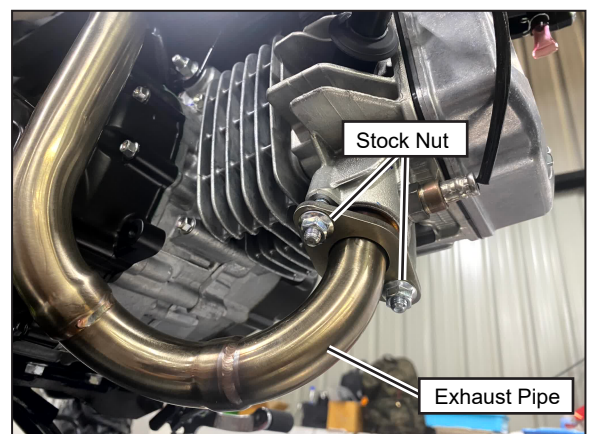

FIG. 5

6) Assemble Exhaust pipe to Silencer Bracket with Cap bolt M8x20, 2-Washer M8x26 and Flange Nut M8
Tighten bolts by hand only at this stage. (See Fig. 6)

7) Install Silencer Assy to Exhaust Pipe and fix them with Exhaust Spring (See Fig. 7).

CAUTION Make sure that exhaust spring is hooked to spring installation tool firmly
If neglected, it may cause injury.

8) Assemble Silencer Bracket to Silencer Assy with 2 of each Button Bolt M6x20, Washer M6x13 and Flange Nut M6
Tighten bolts by hand only at this stage. (See Fig. 7 & 8)

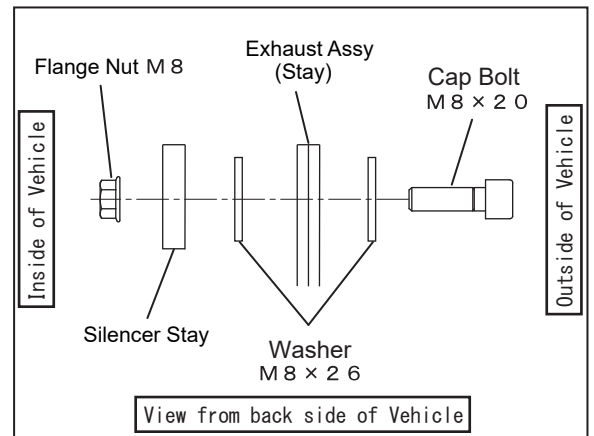

FIG. 6

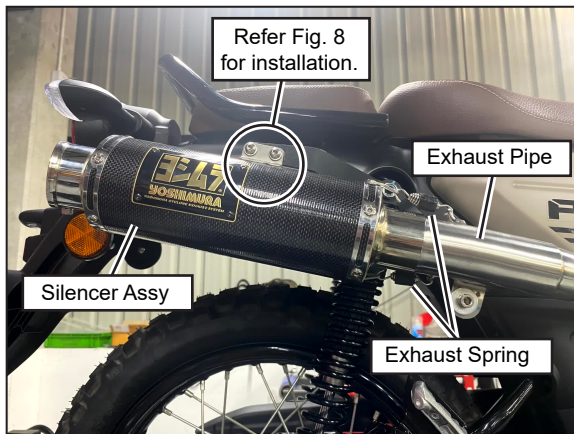

FIG. 7

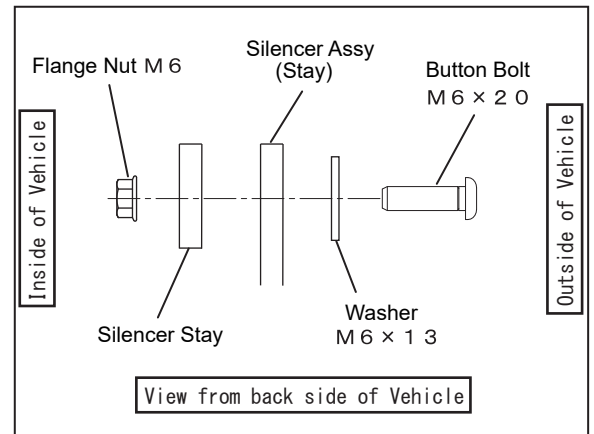

FIG. 8

9) Check that there are proper clearances between Yoshimura Exhaust System and other components. Then, tighten and torque 2 Stock nuts on engine mounting bolt, 2 of button bolt M6x20, Cap Bolt 10x20, U-Nut M10 on RH Upper rear suspension in order. (See Fig. 9 & 10)

Tightening Torque

Stock Bolt at Exhaust Port	: 15 Nm
Button Bolt M6x20	: 10 Nm
Cap Bolt M8x20	: 23 Nm
U-Nut M10	: 28 Nm

CAUTION Torque specification must be followed.



FIG. 9



FIG. 10

- 10) Install Heat Guard on the Exhaust Pipe with 4 of each Button Bolt M6x6 and Washer M6x13

Tightening Torque Button Bolt M6x6 : 10 Nm

- 11) It is recommended that whole exhaust to be wiped down with dish soap to remove oil and fingerprints. This will prevent from tarnishing of finish after exhaust system heats up.

CAUTION When cleaning silencer, use soft cloth with dish soap. Do not use metal polish or parts cleaner. If neglected, Titanium Blue color may tarnish.

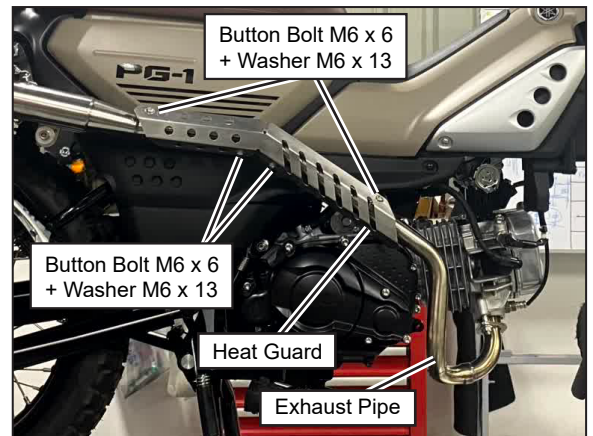

FIG. 11

- 12) Warm-up engine, and inspect exhaust leaking. If "after fire" sounds severely, seal gaps of joint between pipes with heat resistant silicone gasket etc. Then, tighten all bolts and nuts further after engine cools down.

CAUTION Before beginning the work, let motorcycle cool down.

REFERENCE It is normal for new silencer to smoke until inside oil residue burns off.

YAMAHA PG-1

Full System GP-Magnum Type Up



Product Information



Carbon Heat Guard Set Type-1
(PARTS NO. 161-000-A610)



CAUTION

Titanium Blue sleeve is colored by anodizing. Handle with care as the color may change. When cleaning silencer, use soft cloth with dish soap but do not use metal polish or chemical cleaner.

This exhaust is produced for track-day use or for areas where it is not necessary to use a fully legal exhaust. If it is used for racing or on a chassis dynamometer, any damage or carbon discoloration is not included in warranty.

REFERENCE

Yoshimura Asia recommends silencer inner wool replacement every 5,000km (3,000miles) in order to get Yoshimura Asia exhaust performance fully. Climate, riding condition, and frequency of ride are direct contributing factors for inner wool worn out. Keeping high engine revolution also promotes further wool consumption. For silencer repairing, please contact local Yoshimura Asia distributor for further information.

- CAUTIONS AFTER INSTALLATION -

- ⊙ Check each bolt sometimes to see that there is no failure condition such as poor tightening.
- ⊙ Quality control is implemented on all products. If, however, any defect or failure is found, please notify Yoshimura Asia through the selling dealer. Necessary technical service or replacing of the product will be made.
- ⊙ Due to improvement, the specifications and price of the product are subject to change without notice.
- ⊙ For any information regarding this product, please address inquiries to Yoshimura Asia Co., Ltd.

Yoshimura Asia Co., Ltd.

118/3 Moo 18, KLONGNUENG, KLONGLUANG, PATHUMTHANI 12120, THAILAND

Web site: <http://www.yoshimura.asia>